

HMT330 Series Humidity and Temperature Transmitters for Demanding Humidity Measurement



The HMT330 transmitter family has the solution for demanding industrial humidity measurements.

The Vaisala HUMICAP® Humidity and Temperature Transmitter Series HMT330 is designed for demanding industrial applications where stable measurement and wide customization is important.

Vaisala HUMICAP® Performance

The HMT330 series incorporates Vaisala's 30 years of experience in industrial humidity measurement. An updated, even more stable and chemical resistant HUMICAP® sensor is available, next to the proven reliable and accurate sensor.

Chemical Purge Minimizes Effects of Contaminants

In environments with high concentrations of chemicals and cleaning agents, chemical purge option helps to maintain measurement accuracy between calibration intervals.

Chemical purge involves heating the sensor to remove harmful chemicals. The function can be initiated manually or programmed to occur at set intervals.

Features/Benefits

- Six models for demanding industrial applications
- Full 0 ... 100 % RH measurement, temperature range up to +180 °C (+356 °F) (depending on model)
- Pressure tolerance up to 100 bar (depending on model)
- Next generation Vaisala HUMICAP® Sensor for excellent accuracy and stability
- Graphical display of measurement trends and over four-year history
- Multilingual user interface
- Excellent performance in harsh chemical concentrations
- Corrosion resistant IP65 housing
- NIST traceable (certificate included)
- Analog outputs, WLAN/LAN
- MODBUS protocol support (RTU/TCP)



Graphical Display of History and Measurement Trends

The HMT330 can be ordered with a large numerical and graphical display, which allows the user to clearly monitor operational data, measurement trends and 1-year measurement history. The optional data logger with real-time clock makes it possible to generate over four years of measured history, and zoom in on any desired time or time frame. The battery backup of the clock guarantees a reliable logging of measured data.

The display alarm allows tracking of any measured parameter, with a freely configurable low and high limit.

Data Collection and (Wireless) Transfer to PC

The recorded measurement data can be viewed on the display or transferred to a PC with Microsoft Windows® software. The transmitter can also be connected to a network with an optional (W)LAN interface, which enables a (wireless) Ethernet connection. A USB-RJ45 cable makes it easy to connect the service port of the HMT330 to a PC.

Many Ways to Install and Versatile Outputs

Mains and DC power options, and several mounting accessories make the instrument easy to install.

The HMT330 can have up to three analog outputs. Isolated galvanic power supply and relay outputs are also available. For serial interface the

USB connection, RS232 and RS485 can be used.

HMT330 is also capable in applying the MODBUS communication protocol and together with an appropriate connection option provides either MODBUS RTU (RS485) or MODBUS TCP/IP (Ethernet) communication.

Flexible Calibration

The HMT330 instruments are calibrated at six humidity points at the factory. A quick, one-point field calibration can be performed with the hand-held HM70 meter.

A two-point **field** calibration can be performed with the HMK15 salt bath calibrator in a controlled environment. The transmitter can be sent to Vaisala for recalibration. Accredited calibrations and maintenance contracts are also available.

Technical Data

Performance

RELATIVE HUMIDITY

Measurement range 0 ... 100 % RH

Accuracy (including non-linearity, hysteresis, and repeatability)
with Vaisala HUMICAP® 180 or 180R for typical applications
with Vaisala HUMICAP® 180C or 180RC for applications with

chemical purge/warmed probe
at +15 ... +25 °C (59 ... +77 °F) ±1 %RH (0 ... 90 %)

±1.7 %RH (90 ... 100 %RH)

at -20 ... +40 °C (-4 ... +104 °F) ±(1.0 + 0.008 x reading) %RH

at -40 ... +180 °C (-40 ... +356 °F) ±(1.5 + 0.015 x reading) %RH

Factory calibration uncertainty (+20 °C) ± 0.6 % RH (0 ... 40 %RH)
± 1.0 % RH (40 ... 97 %RH)

(Defined as ±2 standard deviation limits. Small variations possible, see also calibration certificate.)

Response time (90 %) at +20 °C (+68 °F) 8 s / 17 s* with grid filter
in still air 20 s / 50 s* with grid + steel netting filter

40 s / 60 s* with sintered filter

* with HUMICAP® 180R or 180RC sensor

TEMPERATURE

Accuracy at +20 °C (+68 °F) ± 0.2 °C (± 0.36 °F)

Accuracy over temperature range (measurement range depends on model)

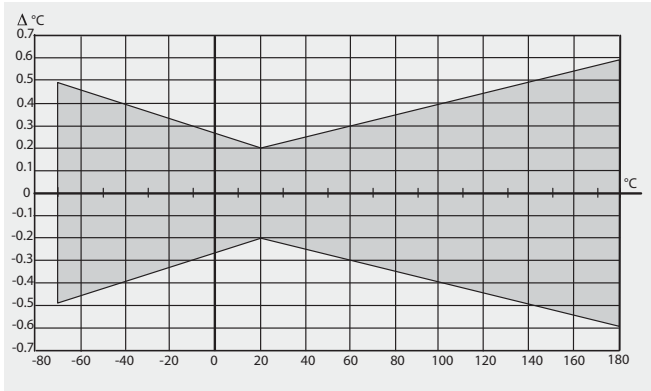

Temperature sensor PT 100 RTD 1/3 Class B IEC 751

Other variables available (depends on model)

dewpoint temperature, mixing ratio, absolute humidity, wet bulb temperature, enthalpy, water vapor pressure

Inputs and Outputs

Operating voltage 10 ... 35 VDC, 24 VAC
with optional power supply module 100 ... 240 VAC, 50/60 HZ

Power consumption at +20 °C (U_{in} 24 VDC)

RS-232 max. 25 mA

U_{out} 2 x 0 ... 1 V/0 ... 5 V/0 ... 10 V max. 25 mA

I_{out} 2 x 0 ... 20 mA max. 60 mA

display and backlight + 20 mA

during chemical purge max. 110 mA

during probe heating (HMT337) + 120 mA

Analog outputs (2 standard, 3rd optional)

current output 0 ... 20 mA, 4 ... 20 mA

voltage output 0 ... 1 V, 0 ... 5 V, 0 ... 10 V

Accuracy of analog outputs at +20 °C ±0.05% full scale

Temperature dependence of the

analog outputs ±0.005%/°C full scale

External loads

current outputs $R_L < 500$ ohm

0 ... 1 V output $R_L > 2$ kohm

0 ... 5 V and 0 ... 10 V outputs $R_L > 10$ kohm

Max. wire size 0.5 mm² (AWG 20)

stranded wires recommended

Digital outputs RS-232, RS-485 (optional)

Protocols ASCII commands, MODBUS RTU

Service connection RS-232, USB

Relay outputs (optional) 0.5 A, 250 VAC

Ethernet interface (optional)

Supported standards 10BASE-T, 100BASE-TX

Connector 8P8C (RJ45)

IPv4 address assignment DHCP (automatic), static

Protocols Telnet, MODBUS TCP/IP

WLAN interface (optional)

Supported standards 802.11b

Antenna connector type RP-SMA

IPv4 address assignment DHCP (automatic), static

Protocols Telnet, MODBUS TCP/IP

Security WEP 64/128, WPA2/802.11i

Authentication / Encryption (WLAN)

Open / no encryption

Open / WEP

WPA Pre shared key / TKIP

WPA Pre shared key / CCMP (a.k.a. WPA2)

Optional data logger with real-time clock

Logged parameters max. four with trend/min/max values

Logging interval 10 sec (fixed)

Max. logging period 4 years 5 months

Logged points 13.7 million points per parameter

Battery lifetime min. 5 years

Display LCD with backlight, graphic trend display of any parameter

Menu languages English, Chinese, Japanese, Spanish, German, French, Swedish, Russian, Finnish

Mechanics

Cable bushing	M20 x 1.5 for cable diameter 8 ... 11 mm/0.31 ... 0.43"
Conduit fitting	1/2" NPT
User cable connector (optional)	M12 series 8-pin (male)
option 1	female plug with 5 m (16.4 ft) black cable
option 2	female plug with screw terminals
Probe cable diameter	
HMT333 (+80 °C)	6.0 mm
other probes	5.5 mm
Housing material	G-AISI 10 Mg (DIN1725)
Housing classification	IP 65 (NEMA4)

Operating Environment

Operating temperature	
for probe	same as measurement range
for transmitter body	-40 ... +60 °C (-40 ... 140 °F)
with display	0 ... +60 °C (32 ... 140 °F)
Electromagnetic compatibility	Complies with EMC standard EN61326-1, Industrial Environment

Mounting Options

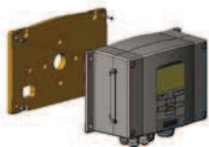

*Mounting with Wall
Mounting Kit*

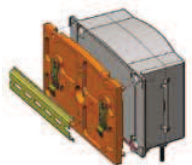

*Mounting with DIN Rail
Installation Kit*

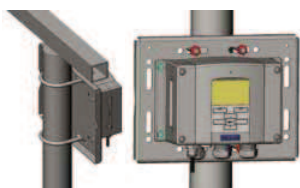

*Pole Installation with Installation
Kit for Pole or Pipeline*

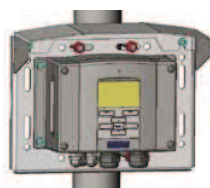

*Mounting Rain Shield with
Installation Kit*

Dimensions

Dimensions in mm (inches)

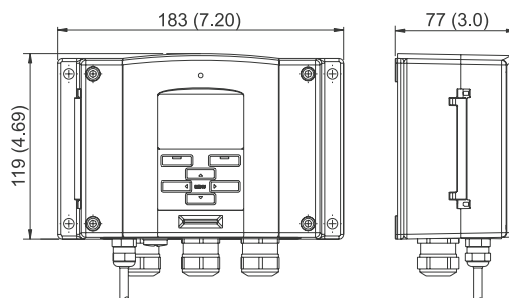

Transmitter with WLAN antenna

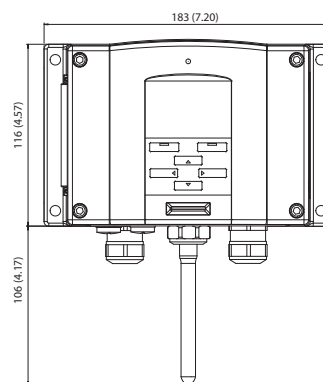

VAISALA

For more information, visit
www.vaisala.com or contact
us at sales@vaisala.com

Ref. B210951EN-C ©Vaisala 2011

This material is subject to copyright protection, with all copyrights retained by Vaisala and its individual partners. All rights reserved. Any logos and/or product names are trademarks of Vaisala or its individual partners. The reproduction, transfer, distribution or storage of information contained in this brochure in any form without the prior written consent of Vaisala is strictly prohibited. All specifications — technical included — are subject to change without notice.



TYPE APPROVED PRODUCT
CERTIFICATE NO.: A-11440



HMT331 Humidity and Temperature Transmitter for Demanding Wall-Mounted Applications



HMT331 Humidity and Temperature Transmitter with short flexible probe and optional WLAN.

The HMT331 is the state-of-the-art wall-mount humidity instrument.

Features/Benefits

- For temperatures -40 ... +60 °C (-40 ... +140 °F)
- Application examples: cleanrooms, pharmaceutical processes, greenhouses, swimming halls, museums and archives

The Vaisala HUMICAP® Humidity and Temperature Transmitter HMT331 is the top-of-the-line wall-mounted transmitter for demanding HVAC and condition monitoring applications.

Compared to regular wall-mounted transmitters, the HMT331 offers, higher measurement performance, better chemical tolerance, advanced graphical display features, more powering options, more output options and a wider variety of output humidity parameters.

Graphical Display of History and Measurement Trends

The HMT330 series features a large numerical and graphical display, allowing users to easily monitor operational data, measurement trends and one-year measurement history.

The optional data logger with real-time clock makes it possible to generate over four years of measured history, and zoom in on any desired time or time frame.

Outputs and Power Supply Options for Every Need

The output options include three analog outputs, RS-232, RS-485, and alarm relays.

The voltage supply range is from 10 to 35 VDC. With an additional module, the transmitter can be connected to all universal mains AC supplies.

The input/output cable can be fed through the back of the transmitter, which is a useful feature, especially for installations in cleanrooms.

Technical Data

Temperature measurement range
-40 ... +60 °C (-40 ... +140 °F)

Accessories

PC software + cable	215005
USB-RJ45 Serial Connection Cable	219685
Connection cable for HM70	211339
Wall mounting plate (plastic)	214829
Pole installation kit	215108
Rain shield	215109
DIN rail installation set	215094

Dimensions

Dimensions in mm (inches)

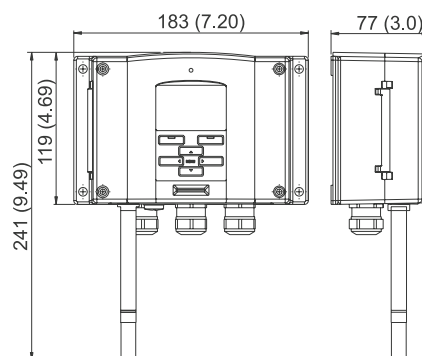

HMT333 Humidity and Temperature Transmitter for Ducts and Tight Spaces



The HMT333 transmitter has a small probe for remote applications.



210697 duct installation kit for HMT333 and HMT337.

For outdoor environments, the DTR502B solar radiation shield provides protection for the probe. The shield can be installed on a pole, a beam or a flat surface.

For Moderate Humidities and Temperatures

The HMT333 is typically used in demanding HVAC applications such as cleanrooms, pharmaceutical processes, and greenhouses, or in processes of moderate temperature.

For environments with continuously high humidity, the HMT337 with a warmed, vapor-tight and stainless steel probe is recommended.

Features/Benefits

- For remote probe installations in demanding HVAC applications
- For temperatures -40 ... +80 °C (-40 ... +176 °F) or -40 ... +120 °C (-40 ... +248 °F)
- Small thermal mass - fast response to temperature changes
- Application examples: cleanrooms, pharmaceutical processes, greenhouses, environmental chambers

The Vaisala HUMICAP® Humidity and Temperature Transmitter HMT333 is a versatile instrument for applications where a small remote probe is needed.

Flexible Installation

To install the probe in ducts, channels and through walls, an installation kit is available with a stainless steel flange, lead-through piece, and steel support bar.

HMT333 has two probe cable options available, a flexible one that withstands heat up to +80° C, and a durable cable that withstands heat up to +120° C. Both cable options are available in lengths of 2, 5, and 10 meters.

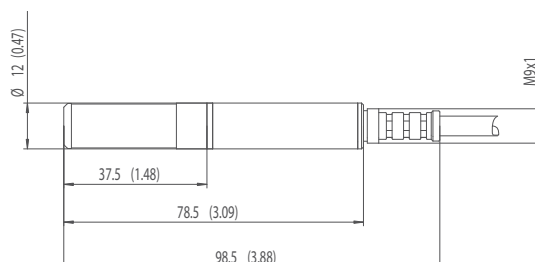

Technical Data

Temperature measurement range
-40 ... +80 °C (-40 ... +176 °F) or
-40 ... +120 °C (-40 ... +248 °F)

Accessories

Duct installation kit	210697
Cable gland	HMP247CG
PC software + cable	215005
USB-RJ45 Serial Connection Cable	219685
Connection cable for HM70	211339
Wall mounting plate (plastic)	214829
Pole installation kit	215108
Rain shield	215109
Solar radiation shield	DTR502B
DIN rail installation set	215094

Dimensions

Dimensions in mm (inches)

HMT334 Humidity and Temperature Transmitter for High Pressure and Vacuum Applications

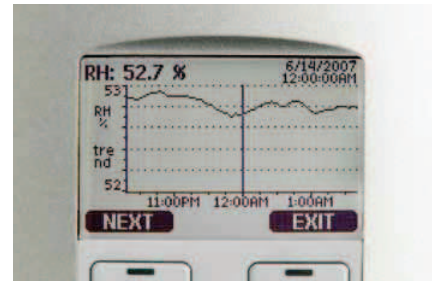

The display shows measurement trends and over four-year real time measurement history.

The HMT334 is ideal for permanent installations into pressurized or vacuum processes.

Features/Benefits

- For pressures up to 100 bar and vacuum applications
- For temperatures -70 ... +180 °C (-94 ... +356 °F)
- ISO and NPT threads available
- Application example: test chambers

Technical Data

Temperature measurement range	-70 ... +180 °C (-94 ... +356 °F)
Operating pressure	0 ... 10 MPa (0 ... 100 bar)

Accessories

Fitting body ISO M22 x 1.5	210697
Fitting body NPT 1/2"	17225
PC software + cable	215005
USB-RJ45 Serial Connection Cable	219685
Connection cable for HM70	211339
Wall mounting plate (plastic)	214829
Pole installation kit	215108
Rain shield	215109
DIN rail installation set	215094

Dimensions

Dimensions in mm (inches)

The Vaisala HUMICAP® Humidity and Temperature Transmitter HMT334 is designed to measure humidity in pressurized spaces or vacuum chambers. Each probe is tested to ensure a gas and vacuum tight installation.

Vaisala HUMICAP® Performance

The HMT334 incorporates Vaisala's more than 30 years of experience in industrial humidity measurement. The sensor provides accurate and reliable measurement and is immune to particulate contamination and most chemicals.

Graphical Display of Measurement Trends and Real Time History

The HMT330 series features a numerical and graphical display. The user can easily monitor operational data, measurement trends and up to one-year history.

The optional data logger with real-time clock makes it possible to generate more than four years of measured history, and zoom in on any desired time or time frame.

Using a serial line, the measurement data can be transferred to a PC where it can be further processed and copied to other programs.

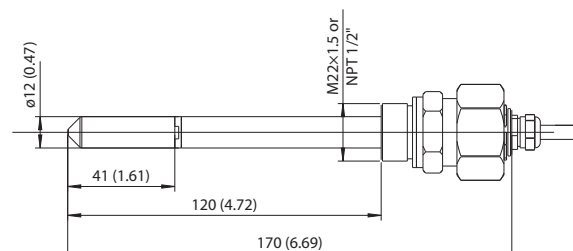

HMT335 Humidity and Temperature Transmitter for High Temperatures



The installation flange allows an adjustable installation depth for the probe.

The HMT335 has a robust stainless steel probe ideal for high flow rates in hot processes.

Features/Benefits

- For temperatures -70 ... +180 °C (-94 ... +356 °F)
- Long metal probe head
- Stainless steel installation flange available
- Adjustable installation depth
- Application example: hot drying processes

Technical Data

Temperature measurement range
-70 ... +180 °C (-94 ... +356 °F)

Accessories

Mounting flange	210696
PC software + cable	215005
USB-RJ45 Serial Connection Cable	219685
Connection cable for HM70	211339
Wall mounting plate (plastic)	214829
Pole installation kit	215108
Rain shield	215109
DIN rail installation set	215094

Dimensions

Dimensions in mm (inches)

The Vaisala HUMICAP® Humidity and Temperature Transmitter HMT335 has a long stainless steel probe designed for high temperatures.

Robust Probe Ideal for High Flow Rates

The HMT335 is ideal for duct measurements as the probe tolerates mechanical stress and withstands high flow rates. The HMT335 can be used, for example, in a hot drying process.

Graphical Display of History and Measurement Trends

The HMT335 features a numerical and graphical display. The user can easily

monitor measurement operational data, measurement trends and one-year measurement history.

The optional data logger with real-time clock makes it possible to generate more than four years of measured history, and zoom in on any desired time or time frame.

Vaisala HUMICAP® Performance

The sensor provides accurate and reliable measurement and is immune to particulate contamination and most chemicals.

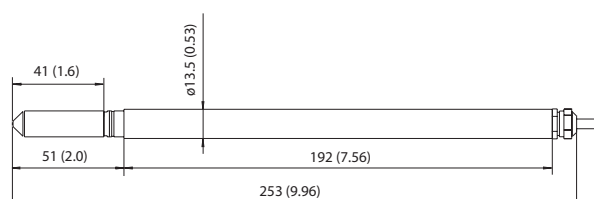

HMT337 Humidity and Temperature Transmitter for High Humidity Applications



The HMT337 is the ideal transmitter for the most demanding process and meteorological measurements.



Duct installation kit

Features/Benefits

- For high-humidity applications in industry and meteorology
- Warmed probe for superior performance in condensing environments
- Small, stainless steel, vapor-tight remote probe
- For temperatures -70 ... +180 °C (-94 ... +356 °F)

Technical Data

Temperature measurement range
-70 ... +180 °C (-94 ... +356 °F)

Accessories

Cable gland and AGRO	HMP247CG
Duct installation kit (RH probe)	210697
Duct installation kit (T probe)	215003
Swagelok fittings (NPT and ISO) for both RH and T probes	
Solar radiation shield	DTR502B
Meteorological inst. kit	HMT330MIK
PC software + cable	215005
USB-RJ45 Serial Connection Cable	219685
Connection cable for HM70	211339
Wall mounting plate (plastic)	214829
Pole installation kit	215108
Rain shield	215109
DIN rail installation set	215094

Dimensions

Dimensions in mm (inches)

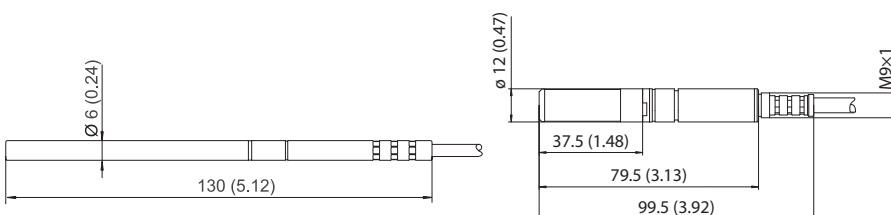

The Vaisala HUMICAP® Humidity and Temperature Transmitter HMT337 is delivered in one of three configurations:

- Basic: non-warmed probe for moderate humidities
- With a warmed probe: for near-condensing conditions and dew point measurement
- With a warmed probe and an additional temperature sensor: for near-condensing conditions and relative humidity measurement

True Humidity Readings in Conditions of Condensation

The Vaisala unique warmed probe provides fast and reliable

measurement in environments where humidity is near saturation. The warming prevents condensation from forming on the sensor.

As the probe is warmed, the humidity level inside it stays below the ambient level. With accurate temperature measurement, the ambient dewpoint can be calculated precisely.

If the relative humidity value is needed, an additional temperature sensor is used. The measured ambient temperature provides the compensation for calculating relative humidity and other humidity parameters.

Many Ways to Install

A tight installation through a process wall can be achieved with Swagelok® fittings. Meteorological installation kits for outdoor installations and duct installation kits are also available.

HMT338 Humidity and Temperature Transmitter for Pressurized Pipelines



The HMT338 is ideal for installations in pressurized processes where the probe needs to be removed while the process is running.

Features/Benefits

- Installed through ball valve
 - can be inserted and removed while the process is running
- Adjustable probe depth
- Pressure tolerance 40 bar
- For temperatures -70 ... +180 °C (-94 ... +356 °F)
- Two probe lengths available

The Vaisala HUMICAP® Humidity and Temperature Transmitter HMT338 is designed for pressurized processes.

Insert or Remove Probe While the Process is Running

With “hot tapping”, the probe is inserted directly into the process while it is running, without the need for venting or lowering the process pressure.

The probe is screwed into a ball valve assembly that has been fixed to the process pipe or wall. The adjustable hex nut is hand-tightened to temporarily hold the probe to the process. Then the probe is pushed

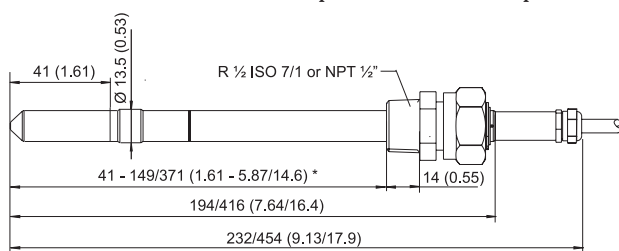

Lengths for standard / optional probes
* freely user-adjustable length

down to the appropriate depth. The hex nut is tightened with a wrench to lock the probe in its place. Hot tapping is possible in pressures up to 10 bar.

Graphical Display of History and Measurement Trends

From the display, the user can easily monitor operational data, measurement trends and one-year measurement history.

The optional data logger with real-time clock makes it possible to generate more than four years of measured history, and zoom in on any desired time or time frame. The battery backup of the real-time clock guarantees a reliable logging of measured data.

Vaisala HUMICAP®

The HMT338 incorporates Vaisala's more than 30 years of experience in industrial humidity measurement. The sensor provides accurate and reliable measurement and is immune to particulate contamination and most chemicals.

Technical Data

Temperature measurement range
-70 ... +180 °C (-94 ... +356 °F)
Operating pressure
0 ... 4MPa (0 ... 40 bar)

Accessories

Ball valve set	BALLVALVE-1
Pressure fitting ISO 1/2 to NPT 1/2	210662
PC software + cable	215005
USB-RJ45 Serial Connection Cable	219685
Connection cable for HM70	211339
Wall mounting plate (plastic)	214829
Pole installation kit	215108
Rain shield	215109
DIN rail installation set	215094

Dimensions

Dimensions in mm (inches)